

DIGI★STAR

P R E C I S E L Y

EZ3410

Operators Manual



DIGI★STAR

Ft. Atkinson, Wisconsin USA

DIGI★STAR

Panningen, The Netherlands

www.digi-star.com

Table of Contents

1.0 INTRODUCTION	4
1.1 Important: Record of Setup, Calibration & Model Numbers	4
2.0 EZ3410 SPECIAL FEATURES	5
3.0 ACCURACY STATEMENT	6
4.0 TECHNICAL SPECIFICATIONS	7
5.0 SAFETY DURING USE	8
6.0 INDICATOR OVERVIEW	9
7.0 OPERATION	11
7.1 Turn on Indicator	11
7.2 Zero Balance Indicator	11
7.3 Tare and Net Gross	12
7.4 Print Key	14
8.0 ADVANCE COMMANDS	15
8.1 Preset	15
8.2 Clear Preset Alarm	15
8.3 Preset-Gross Mode	16
8.4 Preset-Load/Unload Mode	16
8.5 Preset-Net Mode	17
8.6 Preloading a Tare	17
8.7 Mixer Time	18
8.8 Restart Timer for Mixing	19
8.9 Rotation Counter	19
8.10 Re-Starting the Rotation Counter	20
8.11 Setting the Drive Ratio	20
8.12 Maintenance Message	21
8.13 Machine Hour Meter	22
8.14 Review Accumulated Ingredient Values	23
8.15 Erase Accumulated Values	23
8.16 Print Accumulated Values of Active Ingredients	24
8.17 Print Accumulated Values of All Ingredients/Pens	24
9.0 COMMONLY USED DIRECT ACCESS NUMBERS (D.A.N.)	25
9.1 Pre-Alarm	25
9.2 Ingredient –Tolerance Method	25
9.3 Ingredient Tolerance	26
9.4 Pen Tolerance Method	26
9.5 Pen Tolerance	26
9.6 Batch Advance (Ingredient /Pen)	27
9.7 Batch Advance Delay	27
9.8 Manual Pen Advance	27
9.9 Resize Option	28
9.10 Change Time	28
9.11 Change Date	28
10.0 MENUS	29
10.1 Access Menu	29
11.0 MANUAL PROGRAMMING OF RECIPES	30

11.1 Change Entry Method.....	30
11.2 Ingredient Re-name	31
11.3 Print Ingredients Names	32
11.4 Enter New Recipe	33
11.5 Edit Recipe.....	35
11.6 To Erase Ingredient/Pen When Editing Recipes	36
11.7 Erase a Recipe	36
11.8 Review a Recipe	37
11.9 Printing Single Recipe	37
11.10 Printing All Recipes.....	37
12.0 UTILIZING RECIPES	38
12.1 Using Recipes Setup by: Amount per Animal.....	38
13.0 OTHER FUNCTIONS.....	39
13.1 Hold.....	39
13.2 Using LCD Dimmer	39
14.0 SETUP/CALIBRATION	40
14.1 Setup Number.....	40
14.2 Calibration Number	40
15.0 DIRECT ACCESS NUMBERS (D.A.N.)	41
15.1 Options Changed by User	41
16.0 INSTALLATION.....	59
16.1 Indicator Mounting	59
16.2 Cable Connections	62
16.3 Connecting Load Cells to Junction Box	64
16.4 Load Cell Direction.....	64
17.0 OPTIONAL EQUIPMENT.....	65
17.1 Cab Controls (Wireless).....	65
17.2 Data Transfer Options	65
17.3 Transmitter/Receiver	65
17.4 Remote Indicators.....	66
17.5 Rotation Counter Sensor (Kit p/n: 408088)	66
17.6 Printer Option.....	66
18.0 TROUBLESHOOTING	67
18.1 Flow Chart.....	67
19.0 DECLARATION OF CONFORMITY	69
20.0 NOTES	70

D4041-EN EZ3410 Operators Manual Rev A SCC

All rights reserved. Reproduction of any part of this manual in any form whatsoever without Digi-Star's express written permission is forbidden. The contents of this manual are subject to change without notice. All efforts have been made to assure the accuracy of the contents of this manual. However, should any errors be detected, Digi-Star would greatly appreciate being informed of these errors. The above notwithstanding, Digi-Star can assume no responsibility for errors in this manual or their consequence.

© Copyright! 2015 Digi-Star, Fort Atkinson (U.S.A.).

1.0 INTRODUCTION

Thank you for your purchase of a Digi-Star EZ3410 scale indicator. Your EZ3410 is the culmination of more than 30 years of agricultural weighing engineering and expertise. With proper operation and preventative maintenance the EZ3410 will last for many years.

The Digi-Star EZ3410 is primarily designed for weighing agricultural animal feed products during the loading and unloading of mobile and stationary feed mixers. The EZ3410 can also be used on feed delivery boxes, forage wagons, grain carts, and animal scales.

The EZ3410 is not for use with applications for which the EZ3410 is not intended, or as outlined in this manual.

Use of the EZ3410 outside of its intended purposes may result in inaccurate weight measurement or damage to instrument.

1.1 Important: Record of Setup, Calibration & Model Numbers

See Section 14 for how to access the Setup and Calibration numbers that were originally delivered with your indicator and equipment or note the correct or customized Setup and Calibration numbers here.

SETUP NUMBER _____

CALIBRATION NUMBER _____

MODEL NUMBER _____

2.0 EZ3410 SPECIAL FEATURES

Recipe Formulation and Batching

The EZ3410 Indicator is designed to build a choice of recipes for one or more pens and provides easy to utilize basic recipe and batching capabilities. Recipes can be entered by three different methods:

- Amount of each Feed Ingredient, Per Animal
- Percent of Feed Ingredient, Per Load
- Amount of Feed Ingredient, Per Load

Programming recipes is logical and intuitive using the direction keys so that the user can easily add new recipes and edit existing recipes. The user can define and choose from 1 to 99 ingredients and pens using any combination thereof (example 15 ingredients and up to 84 pens). See Section 9.6 for details on how to utilize the Batching capabilities.

Preset Weight

The EZ3410 indicator provides simple to use and very useful Preset Weight feature. Using the numeric keypad the operator can enter the desired weight of product that the operator wants to load or unload. Once loading or unloading begins the EZ3410 will count down to 0 (zero). As the weight approaches 0 the audio and visual alarms will begin to pulse with the frequency of the pulses increasing the closer the preset weight gets to 0. At 0 the alarm light and buzzer will sound continuously. See section 8.0 for details.

Rotation Counter / Timer

The Rotation Counter / Timer provides the useful benefit of monitoring mix revolutions or mix time and a warning light, buzzer, or external signal will indicate when the desired mix revolutions or time has been achieved. For this the EZ3410 uses an optional Rotation Counter Sensor (See Option Equipment Section: 17) which is fitted to the drive line of the feed mixer. See section 17.5

Maintenance Message

The Maintenance Message is available with the Machine Hour Meter function noted above and provides the ability for the equipment manufacturer or equipment owner to utilize the EZ3410 to display a

specific Service or Maintenance message after a predetermined period of operation similar to a Change Oil message in an automobile.

See section 8.12 for details.

Machine Hour Meter

The EZ3410 when fitted with the Rotation Counter Sensor can be configured to record hours of operation. The Machine Hour Meter can provide valuable information to aid the user in determining when maintenance and upkeep is required.

See section 8.13 for details.

3.0 ACCURACY STATEMENT

READ THIS SECTION BEFORE USING THE SCALE SYSTEM

Digi-Star Scale Systems are designed and manufactured to provide the greatest accuracy possible. However, proper installation and use are required in order to obtain the highest level of accuracy.

When using the scale system the following must be considered in order to realize the best possible performance and accuracy.

- Load cells must be installed with the proper orientation. Most Digi-Star load cells have a label indicating either the “TOP” or bending direction of the load cell. Inspect load cells to determine if the load cells are installed correctly. Incorrect installation of load cells will result in inaccurate measurement.
- Load cells should not be subjected to any strains or loads other than the weight of the load. Stress or strain caused by misalignment or other factors when accurate weight readings are desired will negatively affect the accuracy.
- The weighing unit should be stationary with minimum movement, and on a level surface, to insure that weight readings are as accurate as possible.
 - The effect of movement on accuracy depends on the speed and roughness of the ground and application. Rougher terrain and faster and/or greater movement increases the degradation of accuracy.
 - A level surface is defined as being less than a 5” (13cm) change in rise over 10’ (3.0m) of run. As the slope of the terrain increases, degradation of accuracy will also increase.

4.0 TECHNICAL SPECIFICATIONS

SIZE	10.25" long x 8.0" high x 4" wide (260mm x 190mm x 105mm)
WEIGHT	4.5 lbs. (2.04 Kg)
HELP MESSAGES	Context sensitive help messages in 10 languages, Long messages are scrolled
LOAD CELL EXCITATION	8 volts D.C. Nominal, Capable of driving ten 350 Ohms transducers, Short circuit proof
AUTO TEMP COMPENSATION	Of internal circuitry for high accuracy weighing measurements
LOAD CELL SIGNAL	Compatible with Load Cells with greater than 0.25 mv/v
CONNECTORS	AMP plastic weather resistant circular connector. Gold plated contacts.
POWER REQUIREMENTS	10.5 to 16.0 V.D.C. 160 mA nominal with four 350Ω L.C.
SET UP AND CALIBRATION	Via front panel or saved when downloading the setting files.
GROSS RANGE	999,999 max-display
LOW BATTERY WARNING	Enabled at 10.5V nominal
POUND/KILOGRAM	Selectable
DISPLAY	6 Digit Chip On Glass LCD 1.7" high
DISPLAY RESOLUTION	.01, .02, .05, .1, .2, .5, 1, 2, 5, 10, 20, 50, 100
DISPLAY UPDATE RATE	Selectable: 1, 2, 3, 4 times/sec.
MAX. DISPLAY RESOLUTION	Adjustable to 40,000 counts max.
ZERO TRACKING	Selectable, On/Off
SPAN ACCURACY	±(.1% + .005%/ °F) or (.1% + 0.009% °C) full scale ± 1 output count
MOTION DETECTION	Selectable, On/Off
ZERO ACCURACY	(.005%/ °F) or (0.009% °C) full scale ±1 output count for 0.5 mv/v transducer
ENVIRONMENTAL ENCLOSURE	IP65, IEC 529
WEIGH ALGORITHM	3 internally selectable digital filters to optimize performance (General, Slow, and Fast)
HOLD MODE	Used in mobile applications to stabilize displayed weight while moving the scale
NON-VOLATILE MEMORY	Standard
OPERATING TEMP	-29°C to 60°C -20°F to 140°F
2 REMOTE INPUTS (Power/Remote ports)	Tare /Print / Hold / Net Gross / M+ / Zero / TR Hold / Re-enter Preset / Switch/INGRED

5.0 SAFETY DURING USE



Danger: Indicates an imminently hazardous situation that, if not avoided, could result in death or very serious injury.



Warning: Indicates a potential hazardous situation that, if not avoided, may result in death or very serious injury.



Caution: Indicates a potential hazardous situation that, if not avoided, may result in a minor injury.

NOTE!





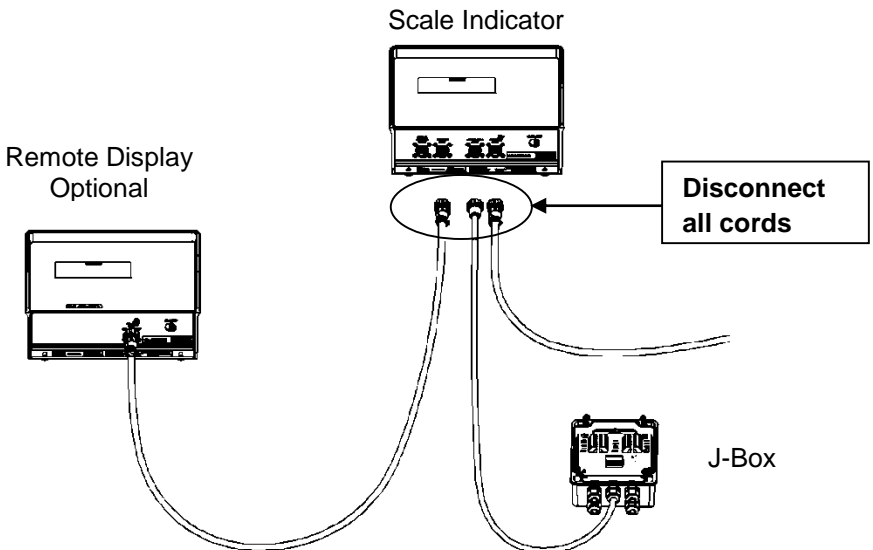



Cleaning: Do not use running water, pressure washer or hoses to clean the indicator or touch screen.

Charging Battery: Disconnect all cables from the indicator and touch screen before charging the battery or welding on the machine. If cables are left connected, the indicator, touch screen and connected load cells could be damaged



6.0 INDICATOR OVERVIEW



- ①  - Press and hold for three seconds to zero balance.
- ② **Re-Alarm Light** - Starts flashing and alarm sounds when weight is within preset limit.
- ③  - Holds displayed weight when moving machine
- ④  - Mixing timer runs down, alarm sounds / Rotation counter is added to count shaft rotations, alarm sounds.
- ⑤  - Turns indicator on. Pressing while on will run self-test.
- ⑥  - Turns scale indicator off.
- ⑦ **Display Window** - Displays current actions.
- ⑧  - Press TARE button for temporary zero when adding more weight.
- ⑨  - Records to memory or prints displayed weight.
- ⑩  - Toggles between NET and GROSS weights.
- ⑪  - Selects recipes in memory

- 12 **ID** – Enter user's ID number and feeding ID number when using the keypad.
- 13 **CLEAR** – Clear the characters on LCD (backspace)
- 14 **SELECT** – Display additional tasks for the user.
- 15 **↔** – Accepts change or proceeds to next item.
- 16 **Directional Arrows** – Moves through list of information. Left arrow (-) and right arrow (+)
- 17 **Keypad** – Input numbers or letters

Indicator Connections Overview

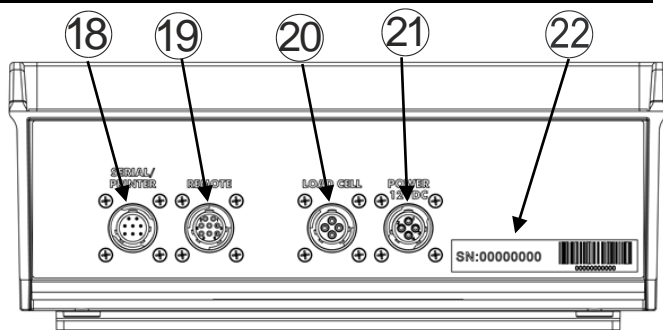

- 18 **Serial/Printer Port** – Communicate with computer and other digital input/output devices.
- 19 **Remote Port** – Optional remote display.
- 20 **Load Cell Port** – For J-Box Cord.
- 21 **Power Port** – For Power Cord.
- 22 **Serial Number Plate** – Serial Number of Indicator.

7.0 OPERATION

7.1 Turn on Indicator

The following procedure is used to turn the indicator ON and OFF.



1. Press **ON** to turn indicator on. Indicator will turn on and say "HELLO", a message may follow, and indicator should then display a number of the weight in the bin.
2. Press **OFF** to turn indicator off.

7.2 Zero Balance Indicator

If the bin is empty and the weight displayed is not zero (0) this procedure will reset the weight to zero (0). **NOTE:** The buildup and removal of debris and feed in a bin will cause the weight of an empty bin to change over time. In addition changes in temperature over time can also cause changes in the displayed weight. The Zero Balance function is provided to counteract these natural events



1. Press and hold **ZERO** for three seconds to zero balance scale.
2. Indicator will display *ZERO* and will then display 0.
3. Flashing arrow on side of display points to gross next to the display window, scale is ready to weigh.

7.3 Tare and Net Gross

Tare is function of the scale where a temporary zero weight (NET) can be set while the total weight (GROSS) is retained in memory. Tare is a useful function that makes it easier to add specific amounts of ingredients to a bin that already contains material. To switch from the

NET to GROSS, or from GROSS to NET press .



1. Starting weight is displayed. Example: 4000



2. Press  to set weight to zero.

3. Flashing arrow points to net.



4. Add more weight and display reads added weight value.



5. To show total of original weight of 4000 pounds plus added 300 pounds, press



6. Flashing arrow on side of display points to GROSS.



7. Pressing  again shows the net weight of 300. In Net mode flashing arrow points to NET.

7.4 Print Key

The print key has dual function capabilities.

1. When a Printer is connected to serial port of the Indicator pressing PRINT will print the weight displayed on the Indicator along with the time and date. See section 17 for information on the Printer Option.
2. When a Data Download (DDL) Kit is connected to the serial port of the Indicator pressing PRINT will save the weight displayed on the Indicator, along with the time and date, to the DDL device. See section 17 for information on the DDL Kit Option.

NOTE: Indicators without a serial port can have a serial port installed by an Authorized Digi-Star Service Center



1. Press  to send data to printer or PC.
2. Flashing arrow on side of display points to DATA.

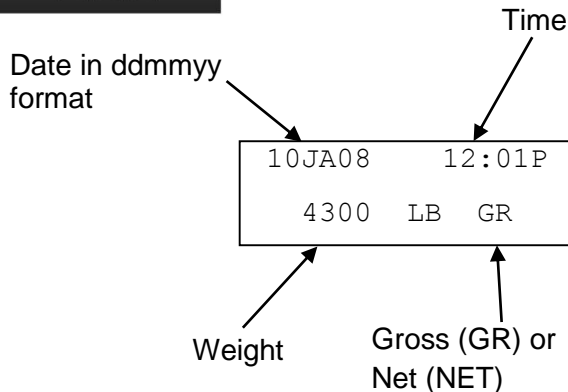

8.0 ADVANCE COMMANDS

8.1 Preset

Enter amount to be loaded or unloaded. Alarm sounds as zero is approached.



1. Enter desired preset weight using key pad.
2. Press  (**NOTE:** Indicator rounds weight to nearest display count. If display count is set to 10 and 3004 is entered Indicator will round to 3000).
3. Once preset entered, display shows the weight loaded or unloaded in one of three display modes:
 - Gross Mode
 - Load/Unload Mode
 - Net Mode

8.2 Clear Preset Alarm



1. Press  to clear preset value.

8.3 Preset-Gross Mode



1. Example: Using keypad enter 3000 pounds.

2. Press . As ingredients are loaded the display counts up to the value entered. The display alternates between flashing word *PRESET* and shown weight, until 10 percent of weight is loaded, at which point only the preset weight will be displayed.

8.4 Preset-Load/Unload Mode



1. Example: Using keypad enter 3500 pounds.

2. Press . As ingredients are loaded or unloaded the display counts down from the entered preset value to zero. The display alternates between flashing word *PRESET* and shown weight, until 10 percent of weight is loaded or unloaded, at which point only the preset weight will be displayed.

8.5 Preset-Net Mode



1. Example: Using keypad enter 4000 pounds.
2. Press **NET GROSS** twice.
As ingredients are loaded or unloaded the display counts up from zero to the value entered. The display alternates between flashing word *PRESET* and shown weight, until 10 percent of weight is loaded or unloaded, at which point only the preset weight will be displayed.

8.6 Preloading a Tare



Preloading a Tare is used in special circumstances such as when using a mixer scale to weigh something in a separate bin when only the weight of the material in the bin is desired. This function will only work if the actual weight of the bin is known. The empty “Tare” weight of the bin is preloaded (using the key pad) into the Indicator in order to display the Net weight of the material within the bin.







1. Enter 1103, press **SELECT**.
2. Press UP arrow or **SELECT** to enable this feature.
3. Press **ENTER** to return to weighing mode.
4. Press and hold **ZERO** for 3 seconds to zero balance the indicator.
5. Add load to the bin
6. Enter known weight of unloaded bin using keypad.
7. Press **TARE** to save weight.
8. Press **NET GROSS** for total weight.

8.7 Mixer Time

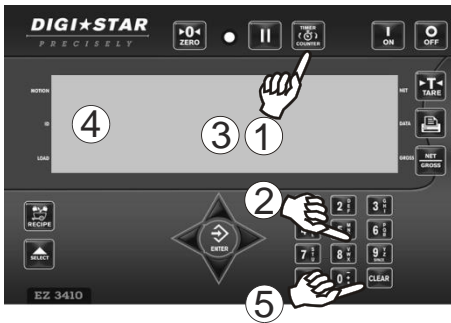
With Mixer Timer enabled, the Indicator performs a stopwatch with alarm function to measure and aid in controlling the length of the mixing time. This function assists the user in maintaining the correct mixing time.

Note: To enable Mixer Timer, enter **4301**, then press  and choose **TIMER** feature using the  button. Press  to save this selection.



1. Press .
2. Use the numeric keypad to enter the amount of time.
3. Press .
4. The time runs down to zero and the alarm sounds. When timer is left running, the display will show a negative time indicating the length of time that the mixer was mixing pass the value the user had entered.
5. Press  to exit.

8.8 Restart Timer for Mixing

Use to re-use the last Mix Time entered into the Indicator.





1. Press  twice, without entering a new value starts the timer using the previous time that was entered.

Example: 7 minutes 30 seconds



8.9 Rotation Counter

With Rotation Counter turned on the Indicator counts the number of mixer rotations during the mixing process. This function assists the user in maintaining the correct mixing based on the number of turns of the mixer. Installation of the optional 408088 Rotation Sensor is required for this functionality.

See section 2.0 for information and section 8.9 for setup

Note: First enter D.A.N. 4301, Press . Choose COUNTER feature and press  to save selection. Indicator will stay in the Rotation Counter mode until this selection is changed.



1. Press .
2. Use the numeric keypad to enter the number of rotations.
3. Press .
4. The Rotation Counter will begin to count down when the PTO starts rotating
5. When the counter reaches 0 the alarm light and buzzer will turn on.
6. Press  to exit.

8.10 Re-Starting the Rotation Counter

Function used to re-use the last Rotation Counter setting that was entered into the Indicator.



1. Press  twice, without entering a new value starts the counter using the previous count that was entered.

8.11 Setting the Drive Ratio

Drive ratio value is: number of turns seen by the Rotation Sensor divided by the number of Mixer rotations. Example: If the PTO turns at 1000 rpm for 1 minute and results in 20 turns of the mixer the Drive Ratio is 50:1.





1. Enter D.A.N. 4302 and press  .
2. Enter drive ratio value using the keypad.
3. Press .

8.12 Maintenance Message

Use to alert the user of maintenance needed to be done on the equipment.

Rotation Counter Sensor Kit--(p/n: 408088) needed for this feature. For proper maintenance schedule, refer to equipment operators manual(s).



1. Enter D.A.N. 8011 then press . The user may edit the maintenance message using keypad.
2. *MANTMG 1* is displayed then edit maintenance message by using keypad.
3. Press  when finished

Example: Pressing key pad “1” one time will show 1, pressing two times will show “A”, pressing three times will show “B”,



Note: There are ten (10) MANTMG windows to enter the Maintenance Message. Six letters, spaces, or numbers, fit in each MANTAG window. The maximum length of the complete maintenance message, including spaces, is 60 characters. The entire message from each of the MANTMG windows will display and scroll as one message.

Example message; “**CHANGE MAIN GEARBOX OIL**” contains 23 characters and will require 4 MANTMG windows setup as; “CHANGE_”, “MAIN_G”, “EARBOX”, “_ OIL_”





8.13 Machine Hour Meter

Sets the number of hours that mixer operates before displaying Maintenance Message. This function requires optional 408088 Rotation Sensor. See section 17.



1. Enter 8012 and press 
2. Enter number of hours for maintenance message to be triggered using the key pad and press .

Example: 50 hours. The maintenance message will be displayed on the indicator after 50 hours of operation.

NOTE: Clearing Maintenance Message Time by entering 8013 and press . Then enter “0” using key pad. Then press  to save, or a new maintenance message time maybe entered by using the key pad, then press . User will need to acknowledge the maintenance message by pressing the  key. Once the allotted time is reached the Maintenance Message will display at each power-up and at every 4 hours of operation until user enters a new value for the Machine Hour Meter.

8.14 Review Accumulated Ingredient Values

Use to display the total amount of each ingredient used since the ingredient was setup or the last time the values were eased.

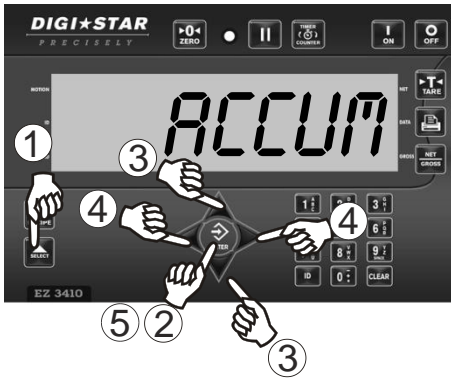

1. Repeatedly press until *ACCUM* displayed.
2. Press .
3. Press UP or DOWN arrow to display accumulation of other ingredients.
4. Press RIGHT arrow to display pens. Press LEFT arrow to display ingredients.
5. Press to exit.

8.15 Erase Accumulated Values





NOTE: Clearing of ingredients and pens are separate, See section 9.9

1. Repeatedly press until *ACCUM* displayed.
2. Press . Ingredient is displayed. Example: *CORN*
3. Press UP or DOWN arrow to display accumulation of other ingredients. Press RIGHT arrow to display pens. Press LEFT arrow to display ingredients.
4. Press and hold indicator scrolls:
CLEAR TO ERASE, CLEAR/CLEAR TO ERASE ALL
5. Press once to erase ingredient displayed.
6. Press twice to erase all accumulation of ingredients for recipe selected.
7. Press to exit.

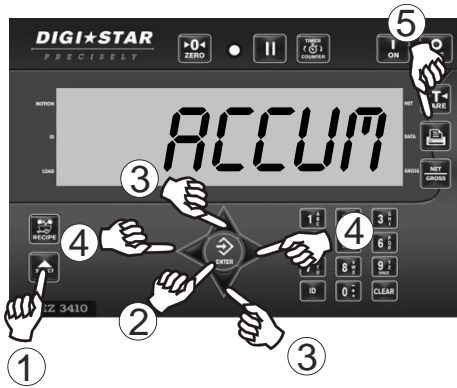



8.16 Print Accumulated Values of Active Ingredients



1. Repeatedly press  until *ACCUM* displayed.
2. Press .
3. Press UP or DOWN arrow to display accumulation of other ingredients.
4. Press RIGHT arrow to display pens. Press LEFT arrow to display ingredients.
5. Press  to print accumulation value for active

8.17 Print Accumulated Values of All Ingredients/Pens





1. Repeatedly press  until *ACCUM* displayed.
2. Press .
3. Press  twice to print all ingredients/pens used in recipes.
4. Press  three times to print all ingredients/pens saved on the indicator.

9.0 COMMONLY USED DIRECT ACCESS NUMBERS (D.A.N.)

9.1 Pre-Alarm

Select weight or percentage method, enter value to activate early warning indicator reaching preset.





1. Enter **4001** and press .
2. Press UP arrow to change between *WEIGHT* and *PERCENT*.
3. Press  to save.
4. Enter Pre-Alarm value. Press  to save.

9.2 Ingredient –Tolerance Method

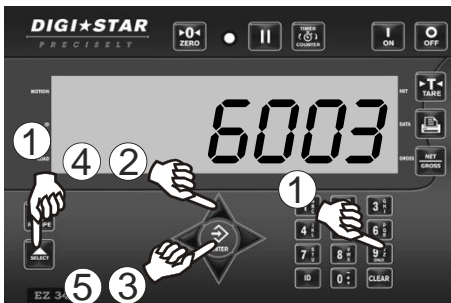
Sets Auto Advance to trigger prior to reaching preset weight by weight or percentage.



1. Enter **6003** and press .
2. Press UP arrow to choose tolerance method.
3. Press  to save.
4. To change percentage, press UP arrow until desired value is shown. To change weight, Enter value.
5. Press  to save.



Note: OFF setting always advances after preset amount reached.

Example: Preset = 1000lb/kg. If tolerance is set to 5%, Auto Advance will activate at 950lb/kg or 95% of preset weight.

9.3 Ingredient Tolerance

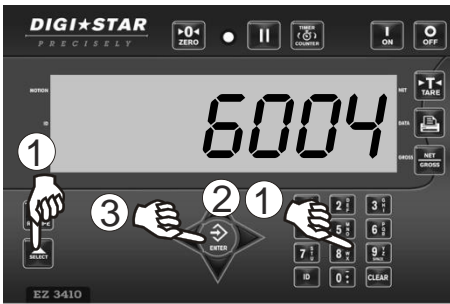
Enter value to accept ingredient for auto advance.







1. Enter **6004** and press .
2. Enter value using keypad to accept ingredient for auto advance.
3. Press .

9.4 Pen Tolerance Method

Select weight or percentage method for pen tolerance.





1. Enter **6005** and press .
- Press  again to choose weight or percent
2. Press , screen will display *PENTOL*.
3. Enter weight or percentage desired.
4. Press .

9.5 Pen Tolerance

Enter value using keypad to accept pen as completed.



1. Enter **6006** and press .
2. Enter value using keypad.
3. Press  to save.



9.6 Batch Advance (Ingredient /Pen)

Allows hands free operation of programmed recipes. When auto advance feature activated, indicator automatically advances to next ingredient/pen, once tolerance, and delay time requirements are met.

9.7 Batch Advance Delay

Select seconds to delay before advancing to next feed-line



1. Enter **6008** and press .
2. Select delay time using key pad.
3. Press .

Note: Set seconds to “0” for manual advance.

9.8 Manual Pen Advance

Pens manually advance and ingredients automatically advance.







1. Enter **6009** and press .
2. Press .
3. Press  again to enable or disable feature.
4. Press .

10.0 MENUS

10.1 Access Menu



1. Press  until *MENU* is displayed.
2. Press and hold  for 3 seconds.
3. Press UP or DOWN arrow to select *MENU 1-5 EXIT*
4. Press  to choose *MENU*
5. Press  again to scroll features in *MENU*.
6. Press UP, DOWN or  to change features.
7. Press  to save selected features.

Note: See Section 15, for more Direct Access Numbers (D.A.N.).

11.0 MANUAL PROGRAMMING OF RECIPES

Three different **Entry Methods** for entering ingredients:

Amount per Animal (this is the default setting)

Allows entry of ingredient amounts required for feeding one animal. Indicator calculates preset amounts required for each ingredient.

Percent (%) Per Load



Allows entry of ingredient amounts as a percent (%) of the total mix. To utilize the recipe the total amount of feed that is required is entered and the Indicator calculates the amount of each ingredient that must be added to the mixer. The total amount of all ingredients entered must equal 100% in this mode.

Amount per Load

Allows entry of the specific ingredient amounts required to create a load. With this method the total amount of recipe is fixed and cannot be adjusted

11.1 Change Entry Method









1. Enter **6101** and press .
2. Repeatedly press  scrolls
Select one of the following entry methods:
 - 1 = Amount per Animal
 - 2 = Percent (%) per Load
 - 3 = Amount per Load
3. Press  sets entry method.

11.2 Ingredient Re-name





Ingredient names are listed in a standard table and can be changed using the following steps:

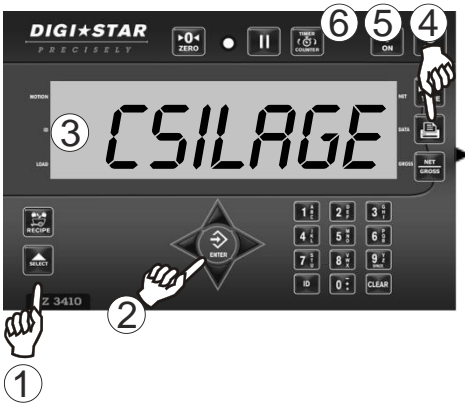

1. Repeatedly press  until *RENAME* displays.
2. Press and hold .
3. Then first ingredient is shown. Use UP or DOWN arrows to select ingredients to edit. (Press RIGHT arrow to display pens. Press LEFT arrow to display ingredients)
4. Press  again to edit ingredient. Display briefly shows *EDIT* and flashing cursor is displayed.
5. Press and hold , erases ingredient
6. Press "1" key once enters 1, twice enters A, three times for B, other numbers on keypads work the same.
7. Pause for one second after entering a number/letter and they shift to the left.
8. Press .
9. When done entering ingredients, press  to exit.

11.3 Print Ingredients Names





1. Repeatedly press  until *RENAME* is displayed.
2. Press and hold .
3. *PROGRAM* is displayed for a moment, then ingredients.
4. Press , prints total accumulations for ingredient displayed
5. Press  again prints accumulations for all currently used recipes.
6. Press  again, prints names for all ingredients. Ingredients not used by recipe and shows unused.

11.4 Enter New Recipe



1. Press and hold  until indicator beeps and displays *PROGRAM* then displays either first recipe programmed or *REC_*.
2. This indicates recipe number can be entered using keypad. Example; *REC-01*, *REC-02*, *REC-03*



3. Press  to add recipe.
4. Press UP and DOWN arrows to scroll ingredients.
5. Press  to select ingredient shown on display.



6. Enter amount of ingredient required. (See note below)
7. Press  to store amount.

Repeat steps 4-7 for each ingredient required.

NOTE: In percent/load entry mode a 75% ingredient, for example, should be entered

As 75.00 on display. 5.75% ingredient entered as 5.75.



8. Press RIGHT arrow to change to pens.
9. Press UP or DOWN arrow to scroll available pens.

10. Press  to select pen on screen.

11. Enter amount for pen.



12. Press  to store amount.

13. Press  completes recipe.





14. Indicator calculates and displays *TOTAL* amount of recipe.

Repeat steps 1-14 until all recipes programmed.

15. Press  to exit.

11.5 Edit Recipe



1. Press and hold  until indicator beeps and displays *PROGRAM*.
2. Press UP or DOWN arrows until recipe number is displayed.
3. Press  to edit this recipe.
4. First ingredient name displayed followed by *AMOUNT*.
5. Enter new amount using keypad.
6. Press , stores and advances to next ingredient.
Repeat steps 5 and 6 for new amounts
7. Press DOWN or UP arrow until *DONE* is displayed
8. Press  to exit recipe being edited.

NOTE: Ingredients / Pens can now be added and removed from a programmed recipe.

9. Press UP arrow to return to previous ingredient.
10. Press and hold RIGHT arrow for three seconds to insert a new ingredient.

NOTE: This will insert the ingredient just before the current ingredient shown on display.

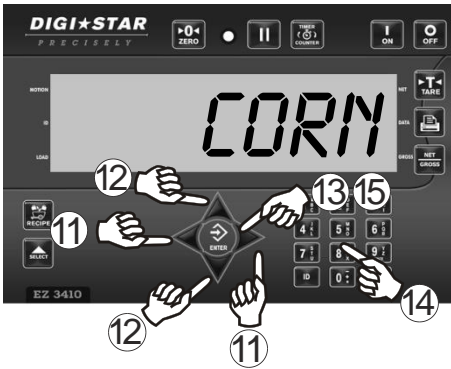



11.6 To Erase Ingredient/Pen When Editing Recipes





11.7 Erase a Recipe



11. Press RIGHT arrow to display pens. Press LEFT arrow to display ingredient
12. Press UP or DOWN arrow to scroll available ingredients or pens.

13. Press  to select ingredient or pen.
14. Enter amount required.
15. Press  to store amount.

1. Press LEFT arrow to erase the current ingredient or pen displayed on the screen.
2. Press  to exit .

1. Press and hold  until indicator beeps and displays *PROGRAM* followed by first recipe number.
2. Press UP or DOWN arrow to select recipe or keypad in recipe number.
3. Press and hold LEFT arrow, message scrolls: *PRESS PRINT TO PRINT RECIPE—PRESS MINUS TO ERASE RECIPE—PRESS NET/GROSS TO EXIT*
4. Press LEFT arrow to erase recipe.
5. Press  to exit.

11.8 Review a Recipe



1. Press .
2. Press UP and DOWN arrows to select recipe
3. Press RIGHT arrow to display each feed-line, weight or percent and total for recipe. (Will Auto Advance through ingredients.)

11.9 Printing Single Recipe

Note: Optional serial port must be installed for printing.



1. Press  displays first recipe.
2. Press UP or DOWN arrows to select recipe.

3. Press  prints recipe.

4. Press .

11.10 Printing All Recipes



1. Press  displays first recipe.

2. Press  twice to print all ingredients/pens used in recipes.





3. Press  three times to print all ingredients/pens saved on the indicator.

4. Press  to exit.

12.0 UTILIZING RECIPES

12.1 Using Recipes Setup by: Amount per Animal





1. Press  to display recipe.
2. Press UP or DOWN arrows to select recipe.
3. Press .
4. Scale indicator displays *ANIMAL RESIZE* for each pen. Then a flashing number is displayed. Enter amount for each pen. Ex: 200
5. Press . **NOTE:** If using percent/load, change number to weight amount for pen.
6. After resizing all pens, indicator displays ingredient to load and how much to load. As ingredient is loaded, indicator counts to zero.
7. Press  to advance to next ingredient.
8. After last ingredient loaded, scale indicator displays *START DELIVERIES -2000 LOADED* Ex: 2000 lbs.
9. Scale indicator displays pen to unload and how much to unload. As pen is unloaded, indicator counts down to zero.
10. Press  to advance to next pen.
11. After last pen unloaded, scale indicator displays *RECIPE COMPLETE TOTAL UNLOADED = 2000*

13.0 OTHER FUNCTIONS

13.1 Hold

Hold mode prevents displayed weight from changing while moving mixer around.





1. Press .
2. Press  again, to return indicator gross weight
3. If weight is added while in hold mode press  to cancel hold.

Note: This feature is disabled on all legal for trade systems.

13.2 Using LCD Dimmer









1. Repeatedly press  until *DIMMER* is displayed.
2. Press . Display back-light will dim.
3. Repeat 1-2 to change display lighting back.

①

15.0 DIRECT ACCESS NUMBERS (D.A.N.)

15.1 Options Changed by User

To display menus 1, 2, 3, 4, 5, 6 :

1. Repeatedly press  until MENU is displayed.
2. Press and hold .
3. Repeatedly press  to select Menus 1, 2, 3, 4, 5, 6 or Exit.
4. Press  displays setting name and allows value changes.
5. Press either  or  to scroll through options for each setting/display.
6. Press  to save setting and next option for menu displays.

Menu 1 General Settings

SETTING [display]	D.A.N NO.	OPTIONS [display] BOLD=DEFAULT		DESCRIPTION
LANGUAGE (LANGAG)	1001	English Dutch French German Italian Portuguese Spanish Danish Hungarian Spanish Polish	[ENGLISH] [NEDERL] [FRANCS] [DEUTSH] [ITAL] [PORT] [ESPAÑ] [DANSK] [MAGYAR] [VESTR] [POLSK]	Select language to be displayed.
DISPLAY RATE (DRATE)	1002	1,2,3,4,6,7,8,9,10		Update display times per second.
SCALE ID SETUP (SCALID)	1003	NEW EZ		Identity of scale location (truck id or Mixer number).
ZERO TRACK (ZTRACK)	1004	ON/OFF		If ON -zero track adjust balance for buildup of snow & mud.

SETTING [display]	D.A.N NO.	OPTIONS [displayed] BOLD=DEFAULT	DESCRIPTION
WEIGH METHOD (<i>W MTHD</i>)	1005	1=General 2=Fast 3=Slow	Select weigh method. The speed the weight changes as shown on the LCD.
1 PRESS ZERO (<i>1 ZERO</i>)	1006	ON/OFF	If ON -press and hold Zero key toZero/Balance scale.
AUTO OFF (<i>AUTOFF</i>)	1007	OFF , 15, 30, 45, 60	Indicator turns off after selected minutes of stable weight.
DISPLAY UNIT (<i>LB-KG</i>)	1008	LB/KG	Display pounds – LB or Kilograms - KG
SCROLL DELAY (<i>SCROLL</i>)	1101	0,1,2,3,4, 5, 6, 7, 8, 9	Scroll rate for cold temperatures 0=normal 9=slowest
SAVE TARE (<i>SAVTAR</i>)	1102	ON/OFF	Saves tare weight to non-volatile memory.
PRELOAD TARE (<i>PRETAR</i>)	1103	ON/OFF	Tare weights can be entered using the numeric keypad.
TIME FORMAT (<i>TIME F</i>)	1201	24 HR AM/PM	Select time format - AM/PM or 24 hours
TIME (<i>TIME</i>)	1202	HH:MM:SS, AM/PM	Enter changes HH:MM:SS (use numeric keypad) use function key to change between HH:MM:SS then choose AM/PM.

SETTING [display]	D.A.N NO.	OPTIONS [displayed] BOLD=DEFAULT	DESCRIPTION
DATE FORMAT (DATE F)	1203	1-mm-dd 2-mm/dd/yy 3-mm/dd/yyyy 4-dd-mm 5-dd/mm/yy 6-dd/mm/yyyy 7-ddmmyy 8-ddmmyyyy	Select date format
DATE (DATE)	1204	Enter ddmmyy	Select key changes date or numerical keys - function key chooses dd/mm/yy.
DATE CHECK (DT CHK)	1205	ON/OFF	Verifies the real time clock has a valid date at power up.
REMOTE INPUT 1 (R1INPT)	1401	TARE , PRINT, HOLD, NETGRS, M+, ZERO, OFF, PRESET, SWITCH	Sets function of remote input line on the power cord.
REMOTE 1 SWITCH MESSAGE (R1MSG)	1402		Message that is displayed for remote input switch condition
REMOTE 1 SWITCH STATE (R1STAT)	1403	OPEN/CLOSED	Set remote input line state that displays message and/or illuminates alarm lamp. D.A.N. 1401 set to "switch".
REMOTE 1 SWITCH MESSAGE TIME (R1TIME)	1404	1...2-9	Set how often the remote switch message is displayed. Once every 1-9 seconds. D.A.N. 1401 set to "switch".

SETTING [display]	D.A.N NO.	OPTIONS [display] BOLD=DEFAULT	DESCRIPTION
REMOTE INPUT 2 (<i>RMIMP2</i>)	1411	TARE, PRINT , HOLD, NETGRS, M+, ZERO, TR HLD, OFF, PRESET, SWITCH	Sets function of remote input line on the remote port.
REMOTE 2 SWITCH MESSAGE (<i>RI2MSG</i>)	1412	OPEN, ,-,+,*,0, 1,2,3, 4,5,6,7,8,9,A,B,C, D,E,F,G,H,I,J,K,L, M,N,O,P,Q,R,S,T,U, -V,-W,-X,-Y,-Z	Message that is displayed for remote input condition. D.A.N. 1411 set to "switch".
REMOTE 2 SWITCH STATE (<i>R2STAT</i>)	1413	OPEN/ CLOSED	Set remote input line state that displays message and/or illuminates alarm lamp. D.A.N. 1411 set to "switch".
REMOTE 2 SWITCH MESSAGE TIME (<i>R2TIME</i>)	1414	0...2-9	Set how often the remote switch message is displayed. Once every 1-9 seconds. D.A.N. 1411 set to "switch".
PROGRAM ID (<i>PRG ID</i>)	1998		Displays current software version
ESTIMATED WEIGHT (<i>EST WT</i>)	1999	Enter weight value using key pad. Then press enter.	Manually adjust Gross weight of scale by changing zero/balance. Press "on" to continue.

MENU 2 - COMMUNICATIONS FEATURES

SETTING [display]	D.A.N NO.	OPTIONS [display] BOLD=DEFAULT	DESCRIPTION
REMOTE (<i>REMOTE</i>)	2001	ON/OFF	If ON indicator communicates with Cab Control Display
SCALE NUMBER (<i>SCL NO</i>)	2002	1,2,3,4,5,6,7,8,9,10,11,12, 13,14,15,16,17,18,19,20, 21,22,23,24	Select scale number for cab control communication
EXTERNAL RADIO (<i>EXTRAD</i>)	2003	ON/OFF	Enables external radio to be connected to the J905 port.
DDL ATTACHED (<i>DDL</i>)	2004	YES/NO	Enables connection of a DDL (Data DownLoader)
SCOREBOA RD MODE (<i>SCOREM</i>)	2101	0 ,1,2,3,4,5,6,7,8,11,12,15,27 ,37,38,39	Select scoreboard output
ZERO OUTPUT (<i>ZEROUT</i>)	2102	Weight displayed= Then press ZERO key and hold for three seconds	Allows zero/balance for SCOREM #11 serial gross weight.
FRONT PANEL ZEROUT (<i>ZEROFF</i>)	2103	OFF /ON	Allows use of the zero key to zero/balance the serial gross weight.
OPERATION STATUS (<i>OPSTAT</i>)	2111	0 , 2	Select operating data to be sent to a Remote Terminal
COM 1 BAUD RATE (<i>CI BD</i>)	2201	1200,2400, 4800, 9600 , 14400, 19200, 38400, 57600, 115200	Sets baud rate for com port #1
COM 1 PARITY (<i>CI PA</i>)	2202	NONE, ODD, EVEN	Sets parity for com port #1

SETTING [display]	D.A.N NO.	OPTIONS [displayed] BOLD=DEFAULT	DESCRIPTION
COM 1 DATA BITS (C1DATA)	2203	7 , 8	Sets data bits for com port #1
COM 1 DELAY (C1 DLY)	2204	0, .10 , .25, .50, .75, 1-5	Selects seconds to delay before advancing to next line.
COM 2 BAUD RATE (C2 BD)	2211	1200,2400, 4800, 9600 , 14400, 19200, 38400, 57600, 115200	Sets baud rate for com port #2
COM 2 PARITY (C2 PA)	2212	NONE , ODD, EVEN	Sets parity for com port #2
COM 2 DATA BITS (C2DATA)	2213	7 , 8	Sets data bits for com port #2
COM 2 DELAY (C2 DLY)	2214	0, .10 , .25, .50, .75, 1-5	Selects seconds to delay before advancing to next line.
TARE AUTO PRINT (TAREAP)	2301	ON/OFF	If ON -tare auto- prints displayed weight.
ONE LINE PRINT (1L PRT)	2302	ON/OFF	If ON -indicator data prints on one line.
AUTO PRINT (APRINT)	2303	ON/OFF	If ON -pressing keys auto-prints weight values.
PRINT FORMAT (PRTFMT)	2304	AUTO , WTONLY, DOWNLD, DT+TM, ID+TM, IDWTTM, BATCH1, PRTAC1, PRTAC2, PRTAC3, PRWTRC, WTRCTM,3200-A, 3200-B, SCLABC	Select alternate & comma (CSV) formats.
PRINT ACCUMULATION (PRTACC)	2305	0	Shows a running total of weights printed.

SETTING [display]	D.A.N NO.	OPTIONS [display] BOLD=DEFAULT	DESCRIPTION
REMOTE DISPLAY (<i>RDISP</i>)	2401	EZ2 , EZ3MUX, COG,NONE	Select type of remote display
REMOTE TERMINAL (<i>RATERM</i>)	2402	ON/OFF	Sends display data to serial remote terminal interface
BAR GRAPH MODE (<i>BARGRP</i>)	2411	OFF, RIGHT , LEFT, MIDOUT, MID IN	Selects output for a bar graph display when used with an RD4000 Remote Display
WEIGHT GRAPH (<i>WTGRPH</i>)	2412	ON/OFF	Enables graph to be used with weight when used with a RD4000 Remote Display.
BAR WEIGHT (<i>BAR WT</i>)	2413	12000	Enter the full scale gross weight for the bar graph display.
PRESET GRAPH (<i>PRGRPH</i>)	2414	ON/OFF	Enables graph to be used with presets when used with an RD4000 Remote Display.
TIMER GRAPH (<i>TMRGRPH</i>)	2415	ON/OFF	Enables graph to be used with timers when used with an RD4000 Remote Display.

MENU 3 - MOTION & WEIGHT			
SETTING [display]	D.A.N NO.	OPTIONS [displayed] BOLD=DEFAULT	DESCRIPTION
DISPLAY COUNT (<i>COUNT</i>)	3001	.01,.02,.05,.1,.2,.5,1,2,5 10 ,20, 50,100	Select display count size of weigh values.
CAPACITY (<i>CRP</i>)	3002	40,000	Enter MAXIMUM weight measurable on scale.
WM1 ADJUST 1 (<i>WMA1-1</i>)	3003	10	Increase this number to smoothing weighing
WM1 ADJUST 2 (<i>WMA1-2</i>)	3004	4	0=off. Use value less than WMA1-1 for quick response weight.
WM1 ADJUST 3 (<i>WMA1-3</i>)	3005	4000	Enter the weight to active quick response weight Default-10% of scale capacity
WM2 ADJUST 1 (<i>WMA2-1</i>)	3006	30 thru 39	Increase this number to smoothing weighing
WM2 ADJUST 2 (<i>WMA2-2</i>)	3007	10 value must be less than 100 and more than 0	10=off. Use value less than WMA2-1 for quick response weight.
WM2 ADJUST 3 (<i>WMA2-3</i>)	3008	4000	Enter the weight to active quick response weight Default-10% of scale capacity
MOTION (<i>MOTION</i>)	3101	ON/OFF	ON = Motion arrow flashes with unstable weight. Prevents: Print, Zero, Tare, Advance
MOTION WEIGHT (<i>MOT WT</i>)	3102	0	Enter weight used to detect motion. 0=Standard detection

MENU 4 - MOTION & WEIGHT

SETTING [display]	D.A.N NO.	OPTIONS [displayed] BOLD=DEFAULT	DESCRIPTION
PRE ALARM METHOD (<i>P MTHD</i>)	4001	WEIGHT, PERCENT	Select weight or percentage method for pre-alarm
PRE-ALARM (<i>P-ALM</i>)	4002	100	Enter a value to activate an early warning that indicator is reaching the preset.
ALARM OUTPUT (<i>AL OUT</i>)	4003	OFF, PRESET , TR	Select preset or TR to control relay, horn & lamp.
BUZZER (<i>BUZZER</i>)	4004	OFF, ON , 1-10	ALARM BUZZER - allows user to turn off alarm horn when loading/unloading
RELAY (<i>RELAY</i>)	4005	OFF, PRESET , SETPNT	Selects the behavior of the +12VDC alarm output
PRESET DELAY (<i>PRTDLY</i>)	4006	0 thru 9	Set time to automatically advance/print entered preset
GROSS SET PNT OUTPUT (<i>SETOUT</i>)	4101	OVER/UNDER	Select when the +12VDC Alarm Output becomes active.
GROSS SET POINT CHNG (<i>SETCHG</i>)	4102	500	Set required weight change to turn off +12VDC Alarm Output.
GROSS SET POINT DELAY (<i>SETDEL</i>)	4103	0 thru 9	Set time delay before the +12VDC Alarm Output can Turn On/Off.
GROSS SET POINT (<i>SETPNT</i>)	4104	5000	Set a gross weight in long form that will activate +12VDC Alarm Output on Power cord.

SETTING [display]	D.A.N NO.	OPTIONS [displayed] BOLD=DEFAULT	DESCRIPTION
SET POINT COUNT (<i>SETCTR</i>)	4105	0 thru 9	Counts how many times set point is activated.
SET POINT WEIGHT SOURCE (<i>STWTSC</i>)	4106	SERIAL/ NORMAL	Sets weight source for use with set point feature.
TOLERANCE METHOD (<i>T MTHD</i>)	4201	WEIGHT, PERCENT	Select weight or percentage method for preset tolerance
SET POINT COUNT (<i>SETCTR</i>)	4105	0 thru 9	Counts how many times set point is activated.
SET POINT WEIGHT SOURCE (<i>STWTSC</i>)	4106	SERIAL/ NORMAL	Sets weight source for use with set point feature.
TOLERANCE METHOD (<i>T MTHD</i>)	4201	WEIGHT, PERCENT	Select weight or percentage method for preset tolerance
TOLERANCE (<i>TOLER</i>)	4202	0 thru 9	Select tolerance weight percentage to accept preset.
TOLERANCE OVERLOCK (<i>OVERLCK</i>)	4203	OFF/ON	Prevents auto-advancing if preset exceeds tolerance
TIMER, COUNTER (<i>TARCTR</i>)	4301	TIMER, COUNTER	Select time or mixer revolutions to decrement mix timer/counter.
DRIVE RATIO (<i>DRATIO</i>)	4302	0001.00	Enter the number of input pulses that equal 1 mixer revolution. REVCTR needs to be enabled in the setup options. D.A.N. 4301 set to COUNTER.

MENU 5 – COM PORT SETUP

SETTING [display]	D.A.N NO.	OPTIONS [displayed] BOLD=DEFAULT	DESCRIPTION
REMOTE DISPLAY PORT (RADPRT)	5001	OFF, COM1, COM2 , COM3	Sets serial remote display output
RADIO PORT (RADPRT)	5002	OFF, COM1, COM2, COM3	Sets internal radio port
EXTERNAL RADIO PORT (EXRPRT)	5003	OFF, COM1, COM2 , COM3	Sets external radio port
PRINTER PORT (PRPRT)	5005	OFF, COM1, COM2 , COM3	Sets printer port
SCOREBOARD PORT (SCPRT)	5006	OFF, COM1 , COM2, COM3	Sets scoreboard port
OPSTAT PORT (OPSTAT)	5007	OFF, COM1 , COM2, COM3	Sets op-stat port
DDL PORT (DDLPT)	5009	OFF, COM1, COM2 , COM3	Sets DDL port
20MA MIRROR PORT (20MMR)	5011	OFF, COM1 , COM2, COM3	Sets port for 20MA signal to mirror
RECIPE PORT (RECPRT)	5012	OFF, COM1, COM2 , COM3	Sets recipe output port
DEBUG PORT (DBGPRT)	5999	OFF , COM1, COM2, COM3	Sets debugger port

MENU 6.0 – APPLICATION SPECIFIC

SETTING [display]	D.A.N NO.	OPTIONS [displayed] BOLD=DEFAULT	DESCRIPTION
BATCH PRE- ALARM METHOD (BPMTHD)	6001	WEIGHT PERCENT	Select weight or percentage method for batch pre-alarm
BATCH PRE- ALARM (BP-ALM)	6002	100	Enter value to activate an early warning that scale is reaching preset.
INGRED. TOLENCE METHOD (ITMTHD)	6003	WEIGHT PERCENT	Select weight or percentage method for ingredient tolerance.
INGREDIENT TOLERANCE (ITOLER)	6004	0	Enter value to accept ingredient for auto advance.
PEN TOLERANCE METHOD (PTMTHD)	6005	WEIGHT PERCENT	Select weight or percentage method for pen tolerance.
PEN TOLERANCE (PTOLER)	6006	0	Enter value to accept pen as completed.
BATCH TOLERANCE OVERLOCK (BOVRLK)	6007	OFF, ON	If ON – prevents auto-advancing if preset exceeds tolerance
BATCH ADVANCE DELAY (BDELAY)	6008	0, MANUAL	Select seconds to delay before advancing to next feed-line.
MANUAL PEN ADVANCE (MANPEN)	6009	OFF, ON	If ON -Overrides Automatic advance for Pens.
INGREDIENT STARTED WEIGHT (ISTART)	6011	40 lbs.	This weight threshold determines if the ingredient has been started.
PEN START WEIGHT (PSTART)	6012	40 lbs.	This weight threshold determines if the pen has been started.

SETTING [display]	D.A.N NO.	OPTIONS [displayed] BOLD=DEFAULT	DESCRIPTION
PEN WEIGHT (PEN WT)	6013	LOAD , GROSS, NET	Select method for displaying pen weight - Net, Load, or Gross.
RESIZE RECIPE (RESIZE)	6014	ON , OFF	If ON - operator can change recipe size.
MENU 6.0.5 – COMMON BATCHING			
RECIPE PRINT FORMAT (RECFMT)	6051	SYSTEM , AUTO, 32-TMR, FDINFO, FEED-1, SERMED	Defines how scale will print when in weighing mode or a batch.
RECIPE TOTAL (RECTOT)	6052	(SCALE)PROG, LAST, PRGCOR, LSTCOR— ON,OFF(PC)	Selects Total amount to be displayed when starting recipe. D.A.N. 6054 select PC or SCALE
INGREDIENT RE-SIZING (INGSIZ)	6053	(PC)OFF , 1 ING, 1+2ING,----(SCALE) OFF , 1ING, 1ING+P	Selects Automatic Ingredient Re-Sizing mode. D.A.N. 6054 select PC or SCALE.
MENU 6.1 – BATCHING			
ENTERY METHOD (EMTHD)	6101	1-amount/animal, 2-percent/load, 3-amount/load	Select batching method. D.A.N. 6054 must be set to “SCALE”
DISPLAY SCOOP % (SCOOP %)	6102	OFF ,ON	If ON - displays scoop percentage to load. D.A.N. 6054 must be set to “SCALE”.
INGREDIENT NAMES (INGRNM)	6103	ON , OFF	If ON - displays ingredient names while batching. D.A.N. 6054 must be set to “SCALE”.
ACCUMULATI ON (ACCU M)	6104	ON , OFF	If ON – load/unload weights accumulated while batching. D.A.N. 6054 must be set to “SCALE”.

MENU 6.2-3610/4610 BATCHING

SETTING [display]	D.A.N NO.	OPTIONS [displayed] BOLD=DEFAULT	DESCRIPTION
FORCE USER ID (USERID)	6201	OFF , ON	If ON - operator MUST enter User ID to use scale.
RECIPE KEYS (RECKEY)	6202	OFF , ON	If ON - disables certain keys when Loading/ Unloading Recipe.
BATCH NUMBER (BATNUM)	6203	PCCTRL , EZCTRL	Select either PC or EZ to control the batch number.
DOUBLE KEY (DBLKEY)	6204	OFF , ON	Ignore extra INGR ADVANCE keys while feeding.
RECIPE REMAIN ACTIVE (RE-USE)	6205	OFF , ON	Allows recipes to be RE-USED for another load.
RECIPE ENTRY METHOD (REENTRY)	6206	RECIPE , BATCH#	Select recipe start method - recipe name or batch number.
SPLIT LOAD (SPLLOAD)	6207	OFF , ON	If ON –Pen presets are re-calculated after each ingredient/pen.
START PRESET WEIGHT (STPRST)	6208	OFF , ON	If ON –Return the starting preset in the timer/bunk read field of feed-line
SMALL INGREDIENT DISPLAY (SMINGR)	6209	0	Enter value to display small ingredient message
UNDONE RECIPES (UNDON)	6211	OFF , ON	If ON - displays all incomplete recipes.
DISPLAY RECIPE PENS (RECPEN)	6212	ON , OFF	If ON - pens are displayed when selecting recipes.

SETTING [display]	D.A.N NO.	OPTIONS [displayed] BOLD=DEFAULT	DESCRIPTION
POWER LOSS MESS (<i>PWRLOS</i>)	6213		If ON - Display time & date of power loss if preset/recipe active.
ERASE DONE FEEDLINE (<i>ERASFD</i>)	6214	OFF, ON	If ON -Erases done feed-lines after data transfer.
MEDIA STORAGE (<i>ASTORE</i>)	6215	QSTART, MANUAL	Select MANUAL, AUTO or Quick START methods for transferring recipe information
RANGE TEST (<i>R-TEST</i>)	6216	OFF, ON	If ON –Feed-lines sent from Data-Link are marked "done". Valid when using Data-Link System.
AUTO START PENS (<i>AUTPEN</i>)	6217	OFF, ON	If ON -Starts Pens List after Recipe is loaded.
FEED ZONE (<i>FOZONE</i>)	6218	ALL, 1, 2, 3, 4, 5, 6, 7, 8, 9	Select feed zone for recipe deliveries.
PARTIAL FEEDING (<i>PARTFD</i>)	6219	OFF, ON	If ON –Partial feedings will be Recorded.
MIMIC TYREL (<i>TC1300</i>)	6221	OFF, ON	If ON - Records preset weights like a Tyrel TCX-1300 Indicator.
SETUP FEATURES			
SIGNON SETTING (<i>SIGNOM</i>)	8001	OFF,ON	Enables continuous display of sign-on message
SIGNON MESSAGE (<i>SIGMSG</i>)	8002	SIGMSG 1,2,3	Enables editing of the sign-on message
MAINTENANCE MESSAGE (<i>MANTMG</i>)	8011	MANTMG 1, 2, 3, 4, 5, 6, 7, 8, 9, 10	Enables editing of the maintenance message

SETTING [display]	D.A.N NO.	OPTIONS [displayed] BOLD=DEFAULT	DESCRIPTION
MAINTENANCE MESS. TIME (<i>MAINTM</i>)	8012	200 , Time is entered using key pad.	Time for maintenance message to be triggered.
DEAD WEIGHT CAL (<i>WT CAL</i>)	8121	Follow instructions shown on LCD	Calibration method using weights
TEMPERATURE CALIBRATION (<i>T CALB</i>)	8123	OFF/ON	On=Scale adjusts for temperature changes
INDICATOR SETUP INFO (<i>DS>SER</i>)	8299	DS>SER	Downloads all setup information to the serial port
KEYTEST	8888		Enables front panel key test

SETUP & CALIBRATION

SETUP NUMBER (<i>SETUP</i>)	8711	146040	Quick entry method selects weigh method 1-4lbs, 5-8 kg, gain 1- 9, display counts 1-9 and capacity *1000
Calibration Number (<i>CAL</i>)	8712	32640	Weight displayed at 0.4mV/V
SETTING [display]	D.A.N NO.	OPTIONS [displayed] BOLD=DEFAULT	DESCRIPTION
Enter the service menu is required to use the 9000 series numbers			
PRESET OPTION ENABLED (<i>PRESET</i>)	90002	PRESET , PREOFF	Allows for entering a target NET weight.
RS232 OPTION ENABLE (<i>RS-232</i>)	90003	RS OFF , RS-232	Enables/disables serial port

SETTING [display]	D.A.N NO.	OPTIONS [displayed] BOLD=DEFAULT	DESCRIPTION
HOLD OPTION ENABLED (<i>HOLD</i>)	90007	HOLD , HLDOFF	Enables the HOLD key functionality
MEMORY OPTION ENABLED (<i>MEMORY</i>)	90008	MEMORY , MEMOFF	Enables/disables the M+, RM, CM options in the SELECT/FUNCTION key menu.
BLACK-OUT OPTION ENABLED (<i>BLKOUT</i>)	90009		Enables functionality to restore the indicator to its previous state before power loss.
TIMER OPTION ENABLED (<i>TIMER</i>)	90011	TMR MX , TMROFF	Allows countdown timer to be set using the TIMER key.
INTERNAL RADIO ENABLED (<i>RADIO</i>)	90012	RA OFF , RADIO	Enables/disables radio—requires radio hardware
ROTATION COUNTER (<i>REVCTR</i>)	90016	REVCTR , REVOFF	Enables/disables rotation counter
NUMBER KEYPAD ENABLED (<i>NUMKEY</i>)	90051	NUMKEY , NUMOFF	If ON—Enables front panel number pad
QWERY KEYPAD ENABLED (<i>QWERTY</i>)	90061	QTYOFF , QWERTY	If ON—Enables QWERTY style keyboard
MODEL IDENTIFICATION (<i>MODELID</i>)	90201	3610	Allow entry of specific model ID to be display at power up.
MODEL ID TIME (<i>MODLTM</i>)	90202	1, 2, 3, 4, 5, 6, 7, 8, 9, 0	If ON---Entry amount of time for MODEL ID to be display at power up.
CLEAR PEAK WEIGHT (<i>CLRPKW</i>)	90302	NO / YES	If ON—Allows clearing of stored Peak weights

SETTING [display]	D.A.N NO.	OPTIONS [displayed] BOLD=DEFAULT	DESCRIPTION
CLEAR ROTATION COUNTER (CLRREV)	90303	NO / YES	Allow clearing of stored rotation counts
CLEAR HOUR METER (CLRHR5)	90304	NO / YES	Allows clearing of hour meter
MAINTENANCE MESS. CLEAR (MANCLR)	90305	0	Allows for clearing of maintenance message time or entry of new time.
REINITIAZE (REINIT)	99999	NO / YES	Reset indicator to factory default settings. 3
GAIN CALIBRATION (GN CAL)	100001	Starts Calibration Timer	Enters gain calibration

16.0 INSTALLATION

16.1 Indicator Mounting

For most applications the equipment manufacturer provides the necessary mounting system and hardware, and mounts the indicator for the end user.

Digi-Star provides a number of mounting options that allow the end user to customize the location and placement of the Indicator. The following section provides a list of the optional mounts.

In all cases the Digi-Star indicator must be securely mounted to the equipment. Loose, or unsupported, indicators can be damaged.

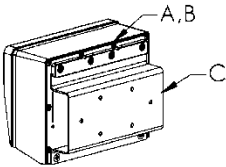

**STD UNIVERSAL
MOUNT TALL**

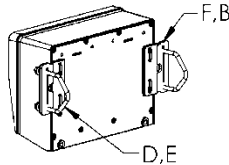

WING MOUNT

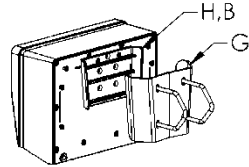

WEDGE MOUNT

Key	Part Number	Description
A	404353	Bracket-EZ3 Plastic Rail
B	403780	SCR-#10 X 5/8 FHSTS Black ZP
C	840459	Support-Hat Bracket
D	405069	U-Bolt 1/4-20 X 3.25 ZP
E	405084	Nut-1/4-20 Top Locking Flange
F	403770	Bracket- Wing Mount
G	405124	Pack-Wedge Mount Bracket With U-Bolts & Flange Nuts
H	405244	EZ3 Wedge Mount

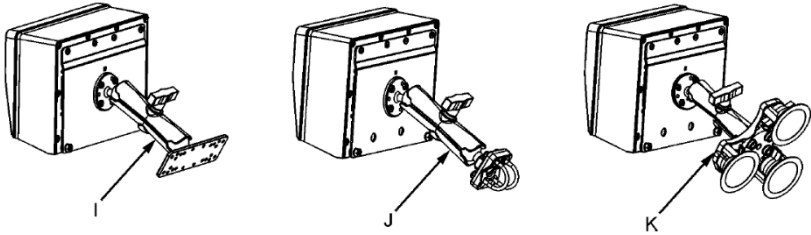

RAM MOUNT

Key	Part Number	Description
I	404799	Kit-1.5" Ram Mount With Bolt-On Base With Hardware
J	407544	KIT-1.5" Ram Mount With Dual U-Bolts (Fits 0.5"-1.5" Round)
K	407434	Kit-1.5" Ram Mount With Triple Suction Cup Base

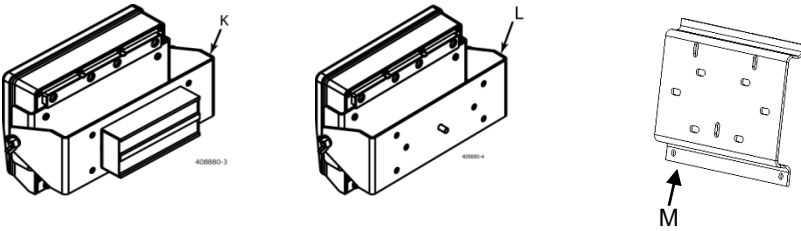

SIDE & UNIVERSAL MOUNTS

Key	Part Number	Description
K	408880	Mount For Large Indicators With Hardware and Magnet
L	408828	Mount for Large Indicators With Hardware Without Magnet
M	408199	Universal Mount Short

16.2 Cable Connections

For accurate and reliable operation care should be taken when routing and connecting cables to the Digi-Star indicator.

- Cables should be secured and protected from damage and abrasion.
- Long cables should not “hang” by the cable connector at the Indicator but should be secured to a structure close to the Indicator leaving a short “tail” to connect to the Indicator.

Special Considerations for Power (+) and Ground (-):

- The Digi-Star indicator is designed to operate at a continuous voltage ranging from 10.5 to 16.0 volts.
- Intermittent voltage drops to as low as 9.0 volts, such as when starting an engine, will be tolerated. Continuous low voltage will result in a low voltage warning on the display or the Indicator will power off.
- Voltage spike above 16 volts will damage the Indicator. Never weld or charge or jump start the battery on the equipment that the indicator is mounted to without disconnecting the indicator power cord. Never operate an indicator on equipment with an engine charging circuit when the battery has been removed.

Digi-Star recommends that the red power (+) and black ground (-) are connected as follows:

- Power (+) can be either switched or keyed ON & OFF, or unswitched and always on.
- Power (+) and Ground (-) should come from a dedicated auxiliary power source when provided. When auxiliary power sources are not provided power should come from the main power distribution system.
 - Fuse or circuit protection of at least 5 amps, but no more than 10 amps, should be provided. Although the Indicator is protected internally by an internal fuse a fuse or circuit protection is required to protect the power cable and equipment.
 - Ground (-) connection should be made to a main ground (the battery ground (-) is often connected to this location). Do not use the chassis or frame of the equipment as a ground.

Indicator Connection Diagram

Pin	To	12VDC Power
1	Red	+Terminal
2	Black	- Terminal
3	Orange	Alarm Out
4	Blue	Remote Input

Scale Indicator

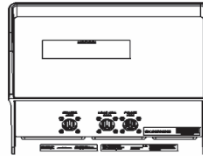

Remote Indicator
(Option)

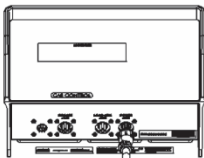

See Indicator
Connection
Diagram

Power Cord

See J-Box
Connections

16.3 Connecting Load Cells to Junction Box

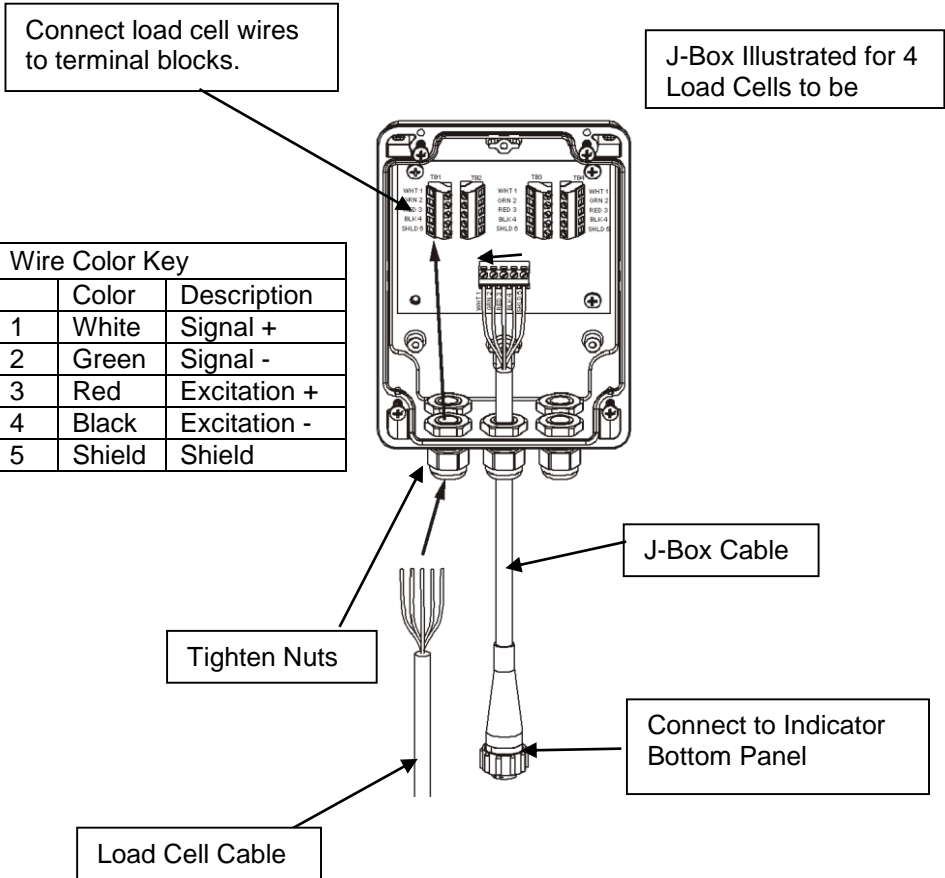

16.4 Load Cell Direction



Observe direction of arrow when installing load cell.

17.0 OPTIONAL EQUIPMENT

17.1 Cab Controls (Wireless)



Features

- Wireless remote with full key control of indicator on mixer
- Mount remote in easy view of loading
- Improves loading accuracy

Functions

- Communicates with multiple mixers

Specification

- Internally mounted 2.4 GHz radios
- Up to 1000 foot range
- 24 channels
- 12 or 24 volt DC system

17.2 Data Transfer Options



Kit Data Down Loader

Allows transfer of data from indicator to PC.

(Optional communication port must already be installed in indicator)

17.3 Transmitter/Receiver



Transmitter (shown) with factory installed receiver in indicator.

Use to zero indicator from a remote location.

Operating range about 90 feet.

17.4 Remote Indicators



RD440 small remote display

RD2400V backlit remote display with 1.7" high numbers

RD2400V backlit remote display w/transmitter and installed receiver

RD2400 backlit remote display with 1" high numbers

RD2400 backlit remote display w/transmitter and installed receiver

RD4000 remote display

17.5 Rotation Counter Sensor (Kit p/n: 408088)

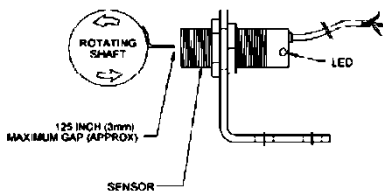

Use with EZ3410 indicator. Sensor allows operator to program indicator to count auger or PTO rotations for accurate mixing of feed. Also used for keeping maintenance log for equipment. Example; At 50 hours of operation time PTO shaft is scheduled for greasing or engine oil is scheduled for changing.

For proper equipment maintenance needed, refer to equipment operator manual.

17.6 Printer Option



Use with EZ3410 indicator, optional communication port must be installed. When a Printer is connected to serial port of the Indicator pressing PRINT will print the weight displayed on the Indicator along with the time and date. See Section 15, D.A.N. 2304 for more print format features

18.0 TROUBLESHOOTING

18.1 Flow Chart

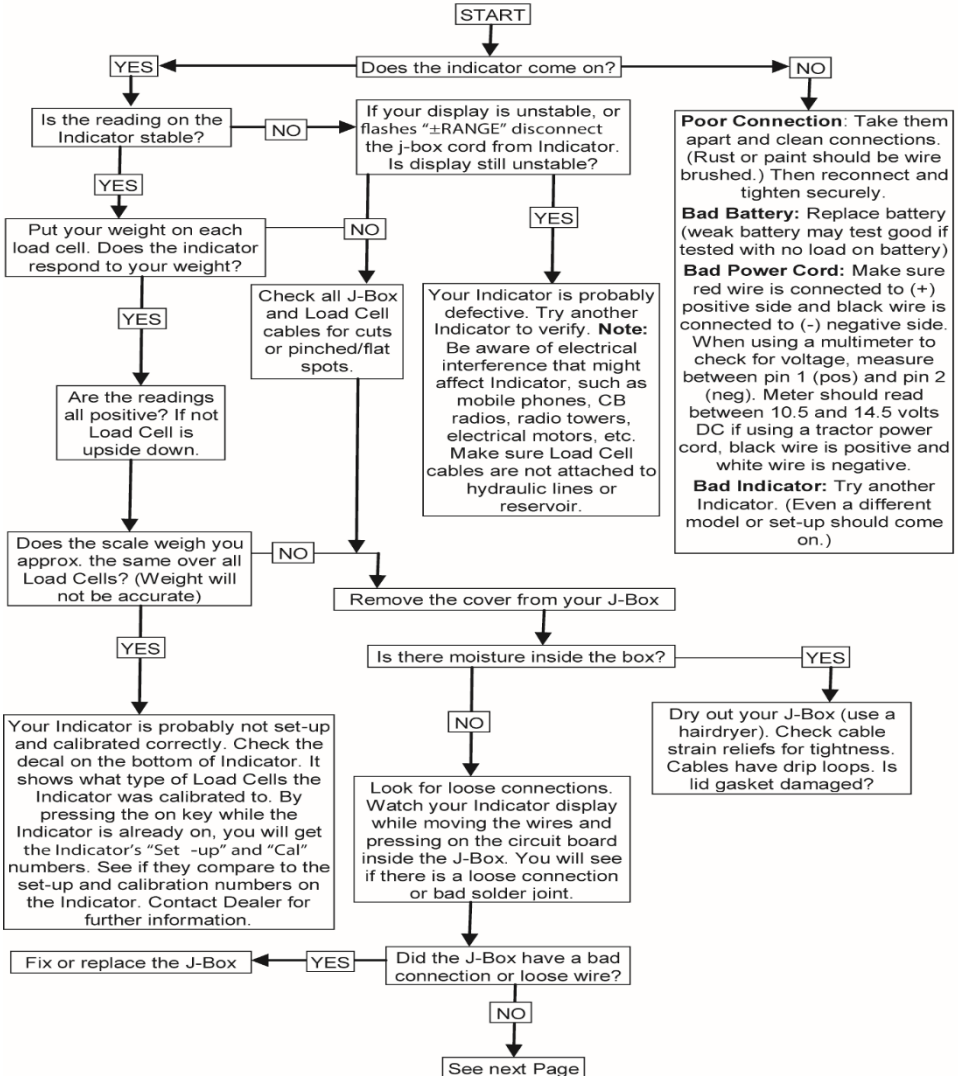

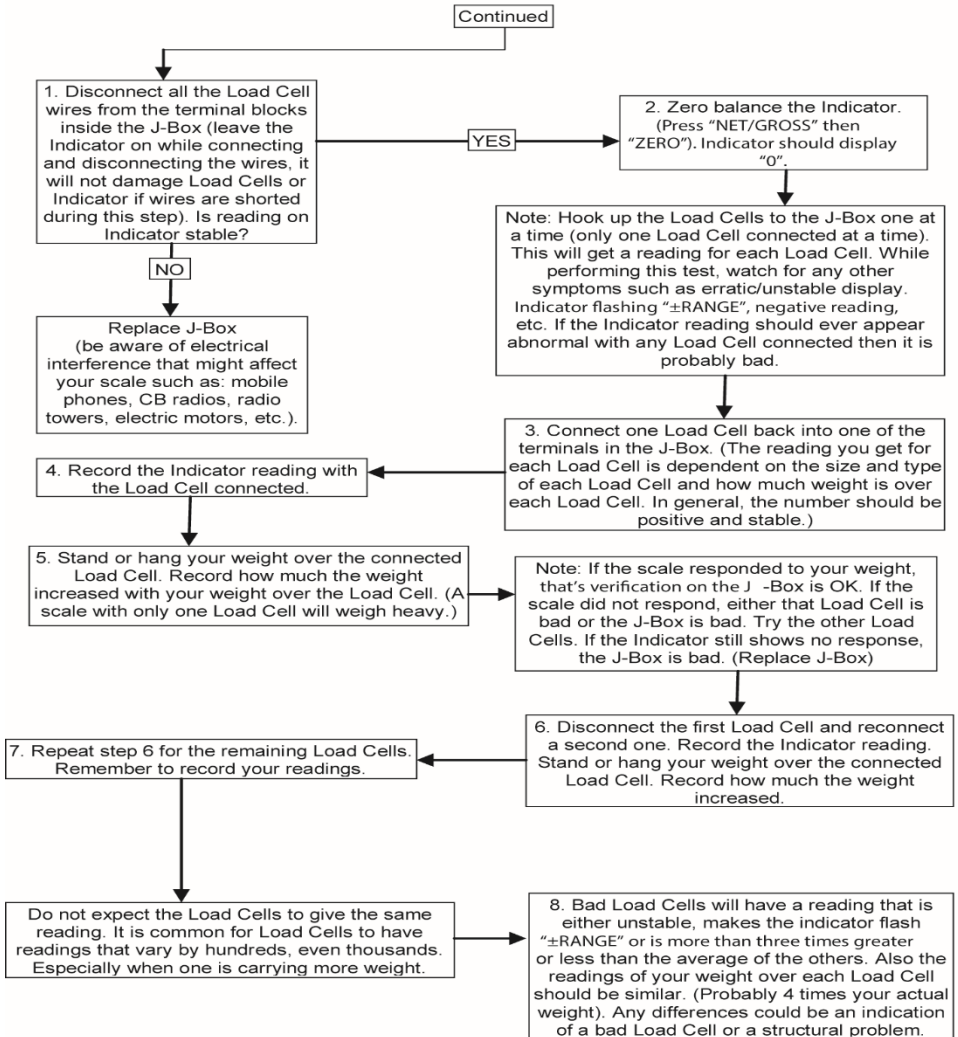

19.0 DECLARATION OF CONFORMITY

EMC DECLARATION OF CONFORMITY	
Application of Council Directive(s)	2004/108/EC
Manufacturer's Name:	Digi-Star, LLC
Manufacturer's Address:	W5527 State Hwy 106 Fort Atkinson, WI 53538
European Representative Name:	Digi-Star International
European Representative Address:	J.F. Kennedylaan 235 5981 WX Panningen The Netherlands
Model Name	TMR3610, EZ2810
Conformance to:	§ EN 61326-1 electrical equipment for measurement, control, and laboratory use (See Report Number 314363.) § EN 55011, for Class B ISM equipment for industrial, scientific, and medical equipment. (See Report Number 314363.)
Equipment Type/Environment:	Electronic weighing scale systems; not legal for trade. For agricultural, commercial and industrial use.
Beginning Serial No.:	00001001
Year of Manufacture:	2015
We, the undersigned, hereby declare that the equipment specified above conforms to the above Directive(s).	
Manufacturer	Legal Representative in Europe
	
Signature	Signature
Full Name: Steven Gorseth	Full Name: Wim de Wit
Position: Director of Engineering	Position: Managing Director
Place: Fort Atkinson, WI U.S.A.	Place: Panningen, The Netherlands
Date: Jan 23, 2015	Date: Jan 23, 2015

20.0 NOTES